



4W Super Mini Ext. Ku-Band Block Up Converter

KEY FEATURES

- ◆ Output frequency 13.75-14.50 GHz
- ◆ L.O. 12.80 GHz
- ◆ Based on GaN technology which enables high efficiency, low power consumption and high reliability
- ◆ Industry's lowest power consumption (19W max.)
- ◆ Smallest package size and weight
- ◆ Powered through IF cable
- ◆ High power efficiency
- ◆ RoHS compliant

ABA4SKX / ABA4SKXF



This smallest and lightest 4W L-To Ku-Band Block Up Converter is based on GaN technology and is designed to be mounted directly on the feed horn. High power efficiency resulting in low current (< 1 amps) consumption allows to use this BUC with any modem without an external power supply.

Mechanical Drawing

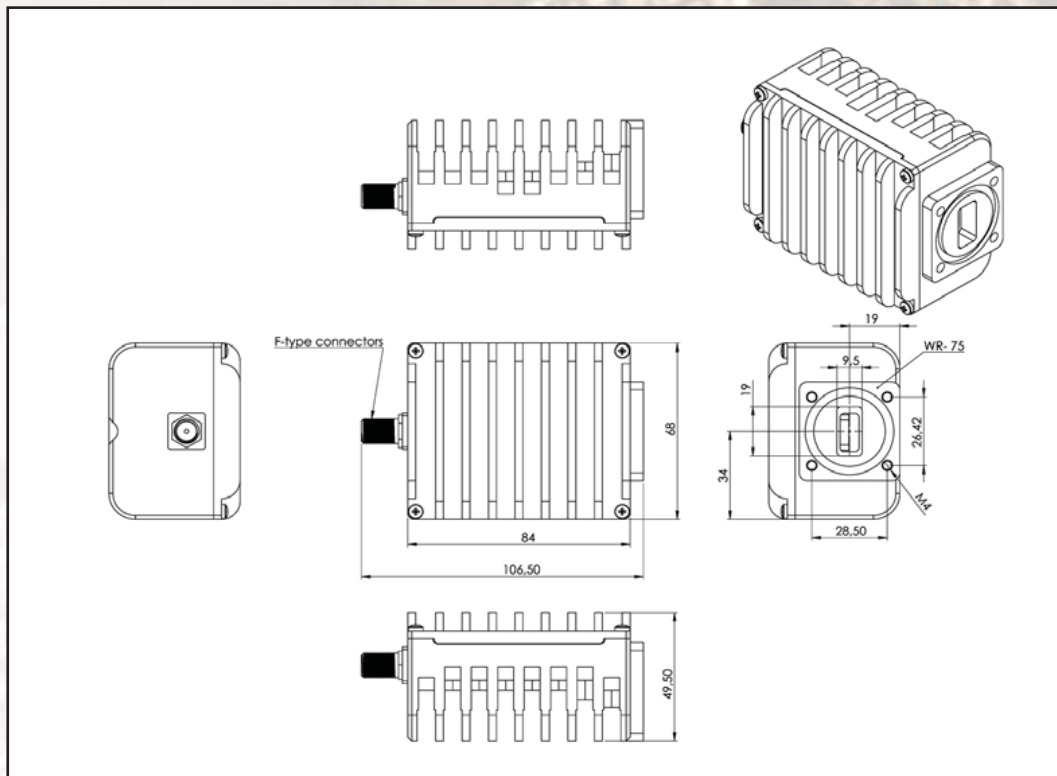



4W Super Mini Ext. Ku-Band Block Up Converter

TECHNICAL SPECIFICATIONS	
RF frequency	13.75 to 14.50 GHz
Local oscillator	12.80 GHz
IF frequency	950 to 1,700 MHz
Output power	4W (+36 dBm min.), P-Linear 2.3W (+33.6 dBm min.)
IF connector	N-type or F-type
Power supply	+15 VDC~+24 VDC via IF cable 19 W max.
Output interface	WR-75 G
Gain	62 dB nominal
IMD3 (two tones)	-26 dBc max. 2 signal 5MHz apart at P-LINEAR
L.O. leakage	-45 dBm max. @RF off
Spurious	-50 dBc max.
Spectral regrowth (QPSK at 1.5x and OQPSK at 1.0x symbol rate offset with 2dB back-off from rated output power)	-30 dBc
Requirement for external reference: frequency input power	via IF cable 10 MHz (sine-wave) -5 to +5 dBm @ input port
TX Gain variation	± 0.5 dB over 40 MHz ± 1.8 dB over full band
TX Gain stability over temperature range	± 1.5 dB typ., ± 1.8 dB max.
Phase noise (Exceeds Intelsat's standard IESS308/309)	-53 dBc/Hz max. @ 10 Hz -63 dBc/Hz max. @ 100 Hz -73 dBc/Hz max. @ 1 KHz -83 dBc/Hz max. @ 10 KHz -93 dBc/Hz max. @ 100 KHz -113 dBc/Hz max. @ 1 MHz
Noise power density	Transmit Receive
	-60 dBm/Hz (max.) -155 dBm/Hz (max.)
Noise figure	20 dB max.
Input V.S.W.R.	1.5 : 1 max.
Output V.S.W.R.	1.5 : 1 max.
Mute	Shut off the BUC in case of L.O. unlocked
Input interface ABA4SKX ABA4SKXF	50 Ohm (N-type IF in) 75 Ohm (F-type IF in)
Temperature range (ambient) operating storage	-40 deg C to +55 deg C -55 deg C to +85 deg C
Vibration and shock	Complies with MIL-STD-810E
IP rating	IP67
Dimensions & housing	84 (L) x 68 (W) x 49.5 (H) mm 3.30" (L) x 2.67" (W) x 1.94" (H)
Weight	0.340 kg (0.75 lbs) max.